

# Light Guide Techniques Using LED Lamps

Application Brief I-003

## What Is a Light Guide?

A light guide is a device designed to transport light from a light source to a point at some distance with minimal loss. Light is transmitted through a light guide by means of total internal reflection. Light guides are usually made of optical grade materials such as acrylic resin, polycarbonate, epoxies, and glass. A light guide can be used to transmit light from an LED lamp on a pc board to a front panel for use as status indication, can be used to collect and direct light to backlight an LCD display or legend, and can be used as the means to illuminate a grid pattern on a see through window. This Application Brief discusses the basics of simple light guide design for these and other possible uses.

## Basic Principles

**Snell's Law:** When light rays are incident to a boundary between two mediums, i.e. plastic and air, the light rays are refracted when they cross the boundary as illustrated in Figure 1. The angle at which the light rays are incident to the boundary is called the angle of incidence,  $\phi_i$ , and the angle at which the light rays leave the boundary is called the angle of

$$\text{Snell's Law} = n_i \sin\phi_i = n_f \sin\phi_f \quad (1)$$

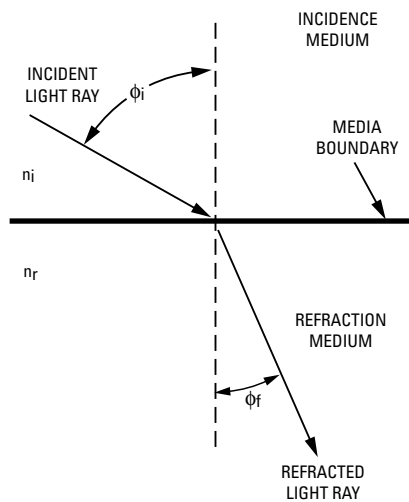

Figure 1. Refracted Light Ray.

refraction,  $\phi_r$ . Snell's law states: the index of refraction of the first medium,  $n_i$ , multiplied by the sine of the angle of incidence at the boundary,  $\phi_i$ , is equal to the index of refraction of the second medium,  $n_r$ , multiplied by the sine of the angle of refraction at the boundary,  $\phi_r$ .

## Specular Reflection

Specular reflection is defined when the angle of incidence equals the angle of reflection as shown in Figure 2. Specular reflected light rays are reflected without loss.

## Fresnel Loss:

When light rays cross the boundary from one medium to another, there is a loss due to reflection at the boundary as shown in Figure 2. This is called Fresnel loss and is calculated with the following expression:

$$\text{Fresnel Loss} = 100 \cdot \left[ \frac{n_i - n_f}{n_i + n_f} \right]^2 \quad (2)$$

For plastic to air and glass to air interface boundaries, the Fresnel loss is 4%.

$$\text{Fresnel Loss} = 100 \cdot \left[ \frac{1.50 - 1.00}{1.50 + 1.00} \right]^2 = 4\%$$

for plastic (glass) to air interfaces.

When light rays cross a boundary into a more dense medium, the angle  $\phi_r$  is less than the angle  $\phi_i$ . Conversely, when light rays cross a boundary into a less dense medium, the angle  $\phi_i$  is greater than the angle  $\phi_r$ . This is illustrated in Figure 3 for light rays passing through a parallel plastic (glass) plate. The light rays are incident to the plate top surface at an angle  $\phi_i$ , are refracted within the plate at the angle  $\phi_r$ , are incident to the

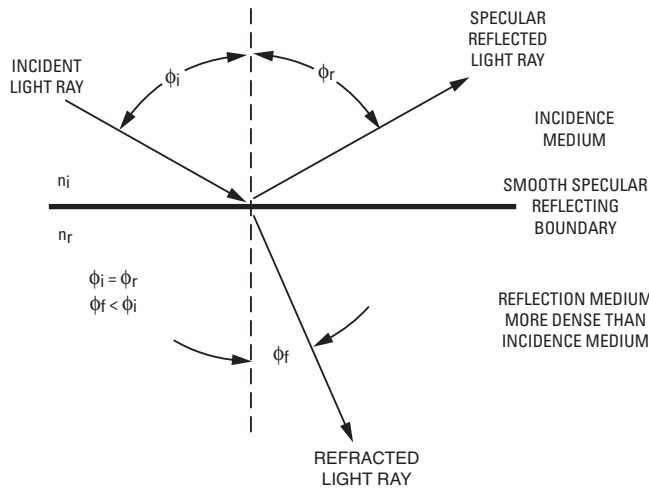

Figure 2. Specular Reflected Light Ray at Mirror Smooth Boundary.

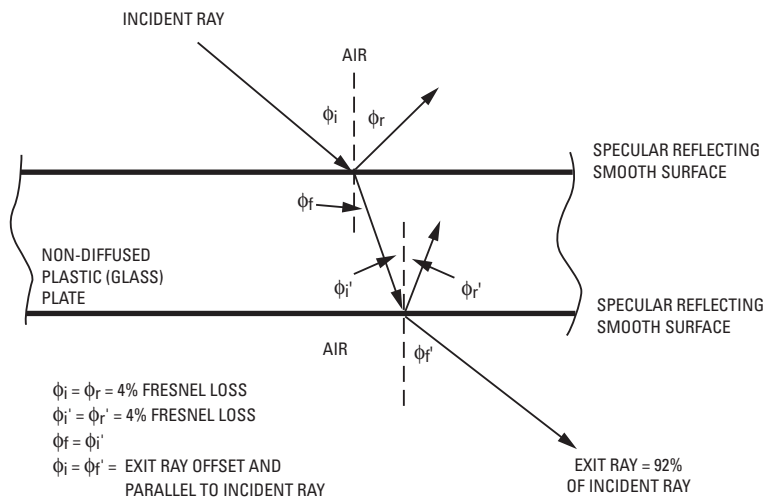

Figure 3. Light Ray Passing Through Nondiffused Plastic (Glass) Parallel Plate.

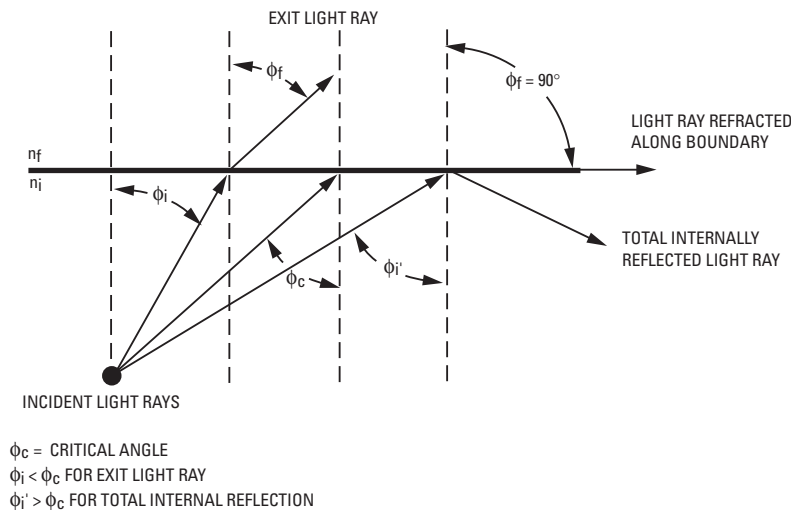

Figure 4. Definition of Critical Angle for Total Internal Reflection.

plate bottom surface of the plate at the angle  $\phi_i'$ , and then are refracted in the air at the angle  $\phi_r'$ . The angle of refraction within the plastic  $\phi_f$  is smaller than the angle of refraction in air  $\phi_r'$  since the plastic is a more dense medium than air. The exit rays are parallel to the incident rays because the internal angle of refraction  $\phi_f$  and the internal angle of incidence  $\phi_i'$  are equal, and because the external angle of incidence  $\phi_i$  and the external angle of refraction  $\phi_r'$  are equal.

**Total Internal Reflection**

When the angle of refraction is  $90^\circ$  the incident light ray is refracted along the boundary, as shown in Figure 4. The  $\sin \phi_f (90^\circ) = 1.0$ , and Equation 1 for Snell's law reduces to:  $n_i \sin \phi_i = n_r$ . This expression can be rewritten to define the critical incident angle for total internal reflection,  $\phi_c$ :

Critical Angle Definition:

$$\sin \phi_c = \frac{n_f}{n_i} \quad (3)$$

Setting  $n_f = 1.0$  in Equation 3, the index of refraction value for air, the critical angle for a light guide can be quickly determined when the material index of refraction is known. For most plastics and glass, the index of refraction is approximately 1.50. Thus, the critical angle for total internal reflection for most light guide materials is approximately  $42^\circ$ . Internal specular reflection within a light guide at the guide surface to air boundary is utilized to help transmit light through the light guide.

$$\sin \phi_c = \frac{1.0}{1.50} = 0.667,$$

$\phi_c = 42^\circ$  approximate value for plastics and glass.

Light rays internal to a light guide incident to guide surface to air boundary are total internally reflected when the angle of incidence is  $42^\circ$  or greater. Having the critical angle being slightly less than  $45^\circ$  for most light guide materials is very convenient because it allows the use of  $45^\circ$  reflecting prism surfaces in light guide designs.

### Ray Tracing

Ray tracing is a technique used to predict the path of light rays into, through, and out of a light guide. The principles of Snell's law, Fresnel loss, and specular reflection are applied at each guide surface to air interface to determine the direction of the light ray. Ray tracing is used in this Application Brief to illustrate the performance of light guide designs.

### Light Guide Design

There are three design issues to be examined when designing a light guide:

- 1) effective flux coupling to get the light from an LED lamp into the light guide with minimal loss,
- 2) transmitting the light through the guide to the exit surface, and
- 3) allowing the light to escape through the exit surface with minimal loss.

### Flux Coupling to Get LED Light into a Light Guide

Flux from an LED lamp must be effectively coupled to the entrance end of a light guide to permit light capture (light to enter the light guide) with minimal loss before it can be effectively transmitted and utilized. Flux coupling and capture are usually ineffective when the LED lamp is external to the envelope of the light guide surface to air boundary, and conversely are effective when the lamp is located inside the light guide surface to air boundary.

With the LED lamp external to the light guide, as shown in Figure 5, effective flux coupling and light capture occur only when the LED lamp radiation pattern angle matches the acceptance pattern angle of the light guide. Thus, effective flux coupling may be very difficult to accomplish and most of the flux from the LED lamp may be lost. Less than 10% of the available flux is typically captured by a light guide with this configuration.

A lens may be used for flux coupling to focus the flux from an LED lamp onto the entrance end of a light guide, as shown in Figure 6. The focused flux should just fill the entrance end of the light guide. Light capture can be up to 80% effective, but does require availability of physical distance to accommodate the focal length of

the lens. The cost of the focusing lens must be added to the cost of the light pipe design.

The best design for most effective flux coupling is to have the LED lamp located inside the envelope of the light guide surface to air boundary. This concept is illustrated in Figure 7a. In this configuration, the LED lamp is embedded into the light guide and all light rays emanating from the LED lamp are captured by the light guide. The light capture effectiveness is 92%, taking into account the Fresnel losses across the air gap. This design concept is recommended for use with dome LED package devices such as T-1  $\frac{3}{4}$ , T-1, and subminiature LED lamps.

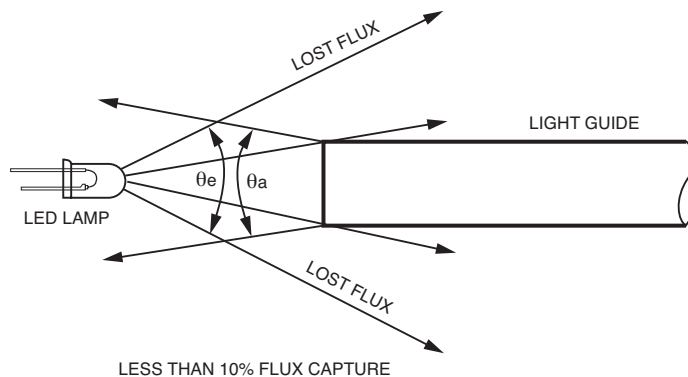

Figure 5. LED Lamp External to Light Guide.

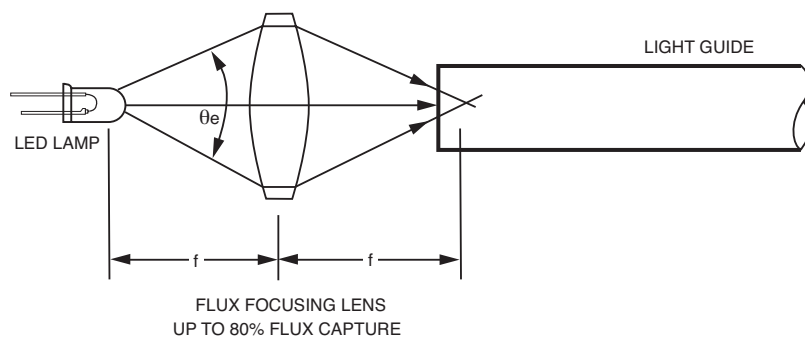
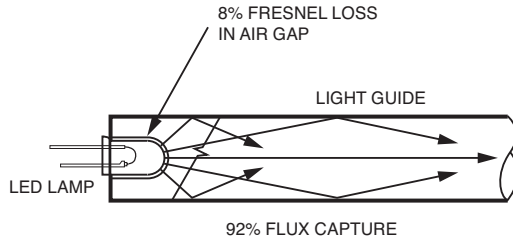
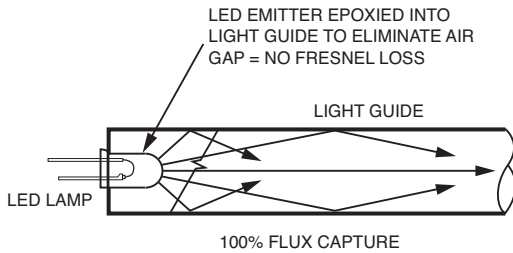

Figure 6. Using a Lens to Focus LED Light Onto Light Guide.



**Figure 7a. LED Lamp Located Inside a Light Guide for Best Flux Coupling.**



**Figure 7b. LED Lamp Epoxied into a Light Guide to Eliminate Fresnel Loss.**

When the LED lamp package is glued into the light guide with an optical grade epoxy, as shown in Figure 7b, the epoxy package of the lamp optically disappears due to the elimination of Fresnel losses, and the flux capture is essentially 100%. In most light guide applications, using epoxy to glue the LED lamp to the light guide to eliminate air gap Fresnel loss is neither practical nor necessary. All of the suggested light guide designs presented in this Application Brief assume there is an air gap between the LED lamp and the light guide.

**Physical Attributes of a Light Guide**

The exterior surface finishes of a light guide are important to assure proper operation, as shown in Figure 8. The sides parallel to the direction of light travel should be smooth, like a mirror, to affect total internal reflection. They may be painted with a white light reflecting paint to reflect those diagonal rays less than the critical angle that may otherwise escape. The entrance end should be smooth, contoured to match the LED lamp device for effective light

capture, allowing light rays to enter the light guide with minimal reflection and scatter. The exit end should be diffused. A diffused exit end has random critical angles across its surface providing a high probability light rays can escape, and also scatters the light rays producing a wide radiation pattern.

Light guides may be made in any desired shape, cylindrical (oval), rectangular (square), conical

(increasing in size from entrance end to exit end), or any special shape (arrow, star shaped, quarter moon, etc.). For rectangular and special shapes, the corners should have a radius greater than 0.5 mm (0.020 in.), not sharp, to assure illumination in the corners. The shape of the light guide may gradually change along its length, i.e. from circular at the entrance end to accommodate the lamp, to square at the exit end, as shown in Figure 8.

**Light Entrance End of Light Guides for Various Types of LED Devices**

For effective flux coupling and light capture, the light entrance end of a light guide should be smooth and flat or concave contoured to match the light output radiation pattern and package configuration of the mating LED lamp device.

For SMT LED lamp devices that have a light emitting area that is a flat surface, the entrance end of the light guide should be a smooth flat surface. The entrance end of the light guide should be placed over and in close proximity to the light emitting surface of the SMT LED lamp for effective flux coupling and light capture, as illustrated in

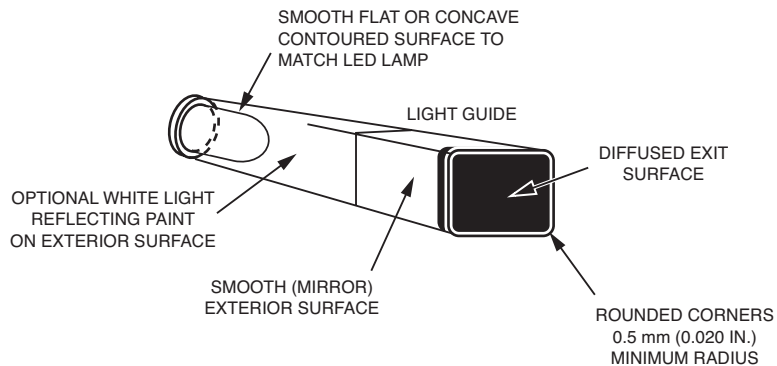

**Figure 8. The Basic Attributes of a Light Guide, shown with a change in shape from Circular to Rectangular along its Length.**

Figure 9. The entrance end of the light guide needs to be slightly larger than the emitting surface of the LED lamp to assure 92% flux capture, taking into account the Fresnel losses across the air gap.

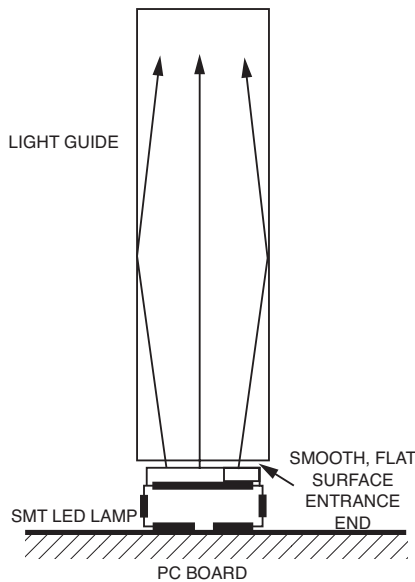

Figure 9. Light Guide with a Smooth Flat Entrance End positioned over an SMT LED Lamp.

SMT Chip LED lamp packages are cubic in shape, diffused, allowing light to emit from the sides as well as the top. Only about 40% of the total available flux is emitted from the top. The other 60% is emitted from the side. Thus, only 40% of the light from an SMT Chip LED lamp would be captured by a light guide with a flat surface entrance end, the remaining flux is lost. A light guide with a smooth concave entrance end to fit over the SMT Chip LED lamp is effective in increasing flux capture, as shown in Figure 10. The smooth concave surface enhances flux coupling and light capture by reducing the possibility of a light ray intersecting the light guide at the critical angle and being reflected. With the concave entrance end, about 70% to 80% of the available emitted flux from an SMT Chip LED is captured by the light guide, and the light loss is reduced to 20% to 30%.

This concave contoured entrance end technique may be used with any light guide/LED lamp

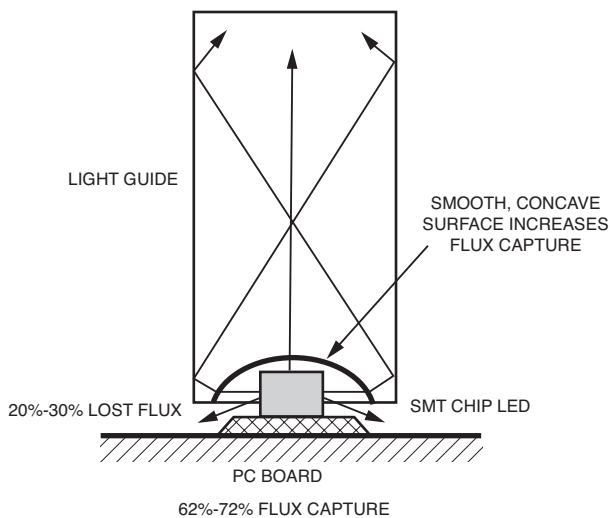

Figure 10. A Light Guide with a Smooth Concave Entrance End increases Flux Coupling and Light Capture from an SMT Chip LED Lamp.

combination to enhance flux coupling and light capture. In Figure 11, a “Yoke” lead SMT subminiature lamp is used to illuminate a light guide located at the back side of a pc board. The lamp is located in a through hole and surface mounted on the component side of the board. The smooth concave surface entrance end of the light guide captures more of the radiated flux from the

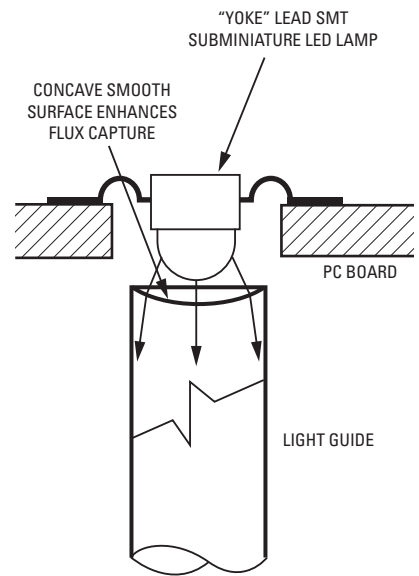
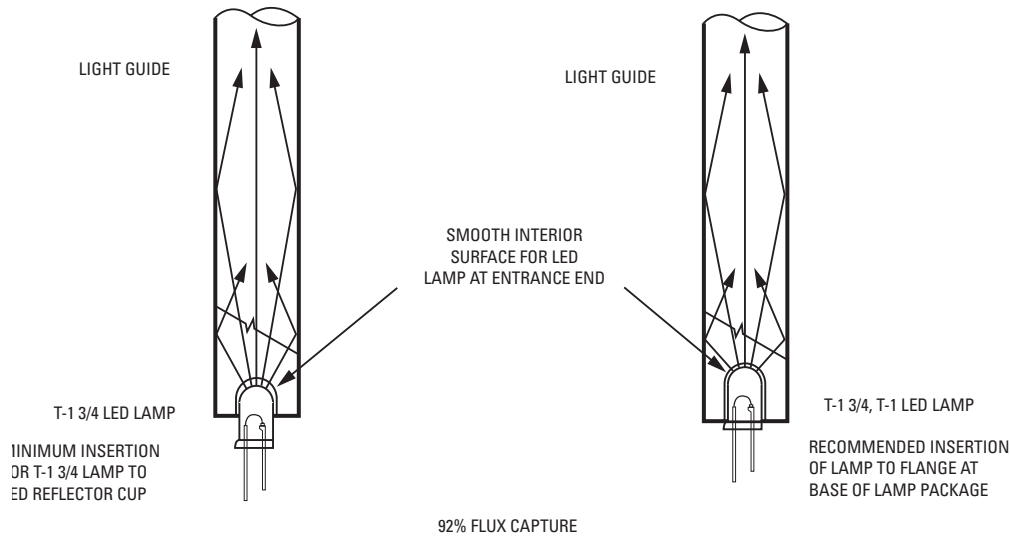

Figure 11. The Concave End of a Light Guide Enhances Flux Coupling and Light Capture From an Inverted Surface Mounted “Yoke” Lead SMT Subminiature LED Lamp.

LED lamp than does a flat surface. As a minimum insertion distance for positive flux coupling and light capture, standard T-1 3/4 untinted, nondiffused LED lamps should be inserted into the entrance end of a light guide up to the LED reflector cup, located within the lamp package, as shown in Figure 12. This assures 92% flux capture, taking into account the Fresnel loss across the air gap between the lamp dome and light guide. For best performance, insertion to the base flange on the lamp package is



**Figure 12. Insertion of T-1 3/4 and T-1 Untinted, Nondiffused LED Lamps into the Entrance End of a Light Guide for Effective Flux Coupling.**

recommended. For T-1 <sup>3</sup>/<sub>4</sub> LED lamps, the lamp acceptance hole should be 5.33 mm (0.210 in.) to 5.59 mm (0.220 in.) in diameter. The end of the hole should be a smooth spherical dome radius. The hole should be at least 5.33 mm (0.210 in.) in depth for minimum length insertion, and 8.31 mm (0.327 in.) minimum in depth for full length insertion. For T-1 LED lamps, the lamp acceptance hole diameter should be 3.30 mm (0.130 in.) to 3.43 mm (0.135 in.) in diameter. Only full length insertion to the lamp base flange is recommended for T-1 lamps to achieve effective flux coupling and capture, with a minimum hole depth of 2.165 mm (0.085 in.).

LED light bars may also be used as light sources for light guides. These devices that have a light emitting area that is a large flat surface. Therefore, for effective flux coupling and light capture the entrance end of the light guide should be a smooth flat surface, placed over and in close proximity to the light emitting surface of the LED light bar, as illustrated in

Figure 13. The entrance end of the light guide needs to be slightly larger than the emitting surface of the light bar to assure 92% flux capture, taking into account the Fresnel losses across the air gap.

**Diffused Exit End of a Light Guide**

A diffused exit end presents random critical angles to internal light rays, assuring the probability

of light escaping from a light guide. This may also be viewed as the diffused exit end having random indices of refraction. The exiting light rays are disbursed at random angles into a wide radiation pattern of light, as shown in Figure 14.

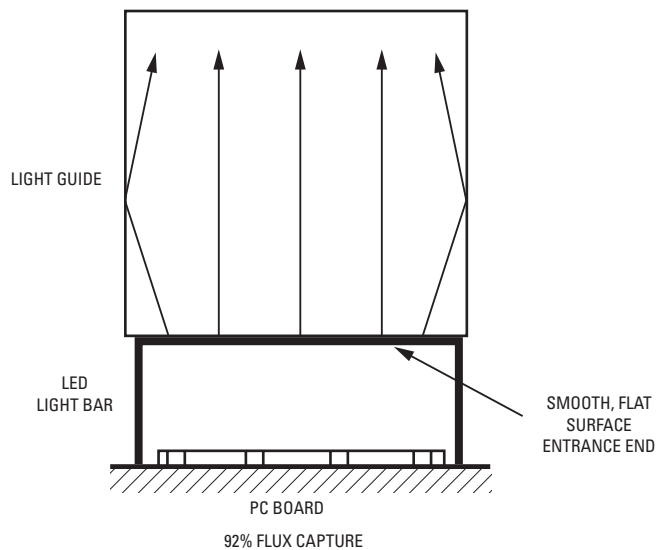

**Figure 13. Light Guide with a Smooth Flat Entrance End Positioned Over an LED Light Bar for Best Flux Coupling.**

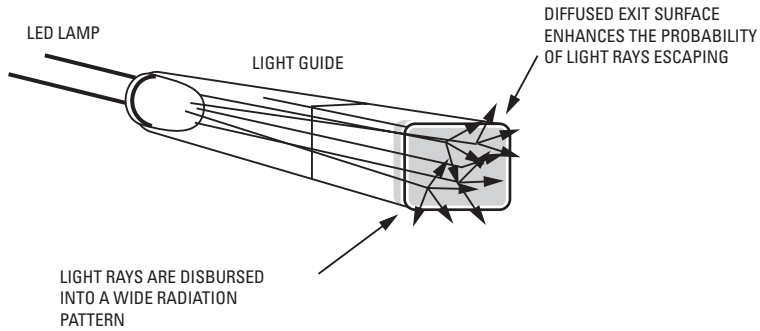

**Figure 14. Diffused Exit End Enhances the Probability of Light Escaping from a Light Guide.**

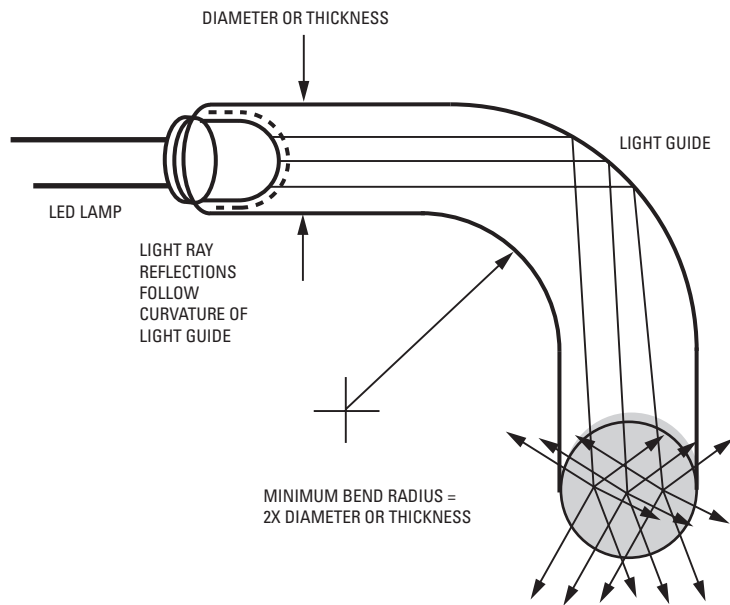

**Figure 15. Light Guide with a 90° Bend. Light Rays are Scattered by Diffused Exit End.**

**Light Guides Around Corners**

Light guides may be bent to go around corners. The bend radius should be equal to or greater than two thicknesses or twice the diameter of the light guide to minimize light loss. The light ray reflections follow the smooth contour of the radius bend without loss, as shown in Figure 15. Sharp right angle direction changes may be achieved by using a reflective prism design in the light guide at the 90° bend location, as shown in Figure 16.

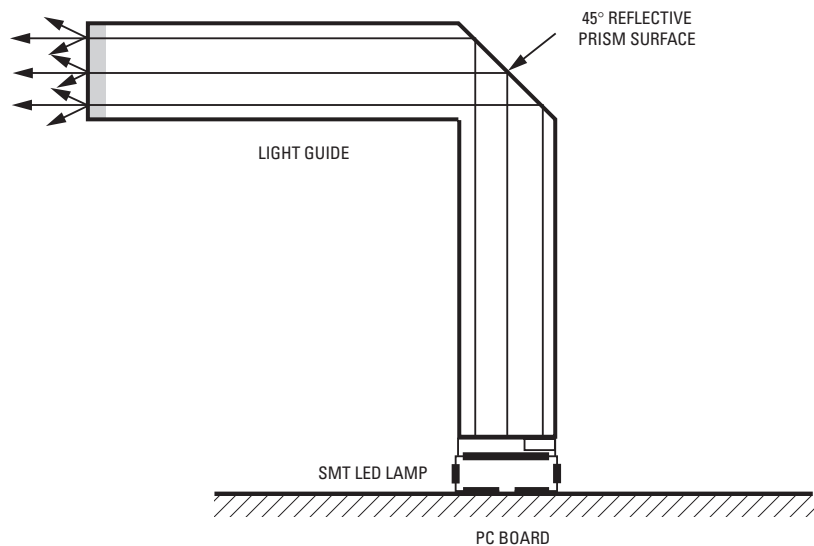

**Figure 16. Light Guide with Built in 45° Prism Reflector.**

### Wedge Light Guides

Wedge shaped light guides may be used to achieve backlighting effects. Two basic kinds are shown in Figure 17, the planar surface wedge which gives a uniform distribution of light and the curved surface wedge which gives a light distribution somewhat logarithmic in nature. The planar surface wedge is typically used to backlight transreflective LCD displays.

### Backlighting Transreflective LCD Displays

Transreflective LCD displays may be backlit with LED lamps using either a simple flat planar light guide or a wedge light guide. For small area LCD displays, 1 to 2 inches high by 2 to 4 inches wide, a simple flat planar light guide may be used, as shown in Figure 18. The top surface of the light guide is diffused to permit light to escape. The edges and backside are smooth. The back surface is coated with white light reflecting paint. Two surface mount pc board assemblies are mounted to the sides of the transparent plate for even illumination. Optional grooves are cut into the plate to provide alignment of the pc board assembly with the plate. The number of SMT LED lamps, spaced on  $\frac{1}{4}$  to  $\frac{1}{2}$  inch centers, depends upon the size of the transparent plate and the required illumination.

A planar wedge light guide may be used with SMT LED lamps for backlighting a medium size transreflective LCD display, i.e. 2 to 3 inches high by 3 to 6 inches wide. A diffusing film interlayer between the LCD and the wedge guide may be used to diffuse the light, as shown in Figure 19. The SMT LED lamps are spaced on  $\frac{1}{4}$  to  $\frac{1}{2}$  inch spacing to achieve even

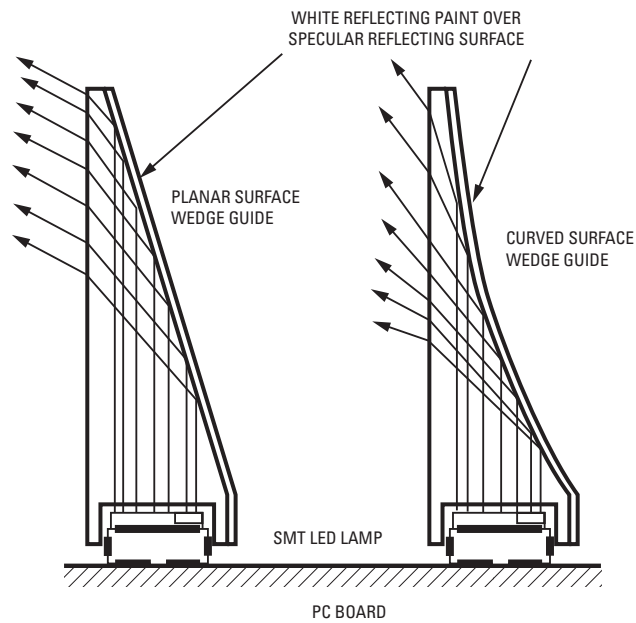

Figure 17. Wedge Light Guides, Planar Surface and Curved Surface.

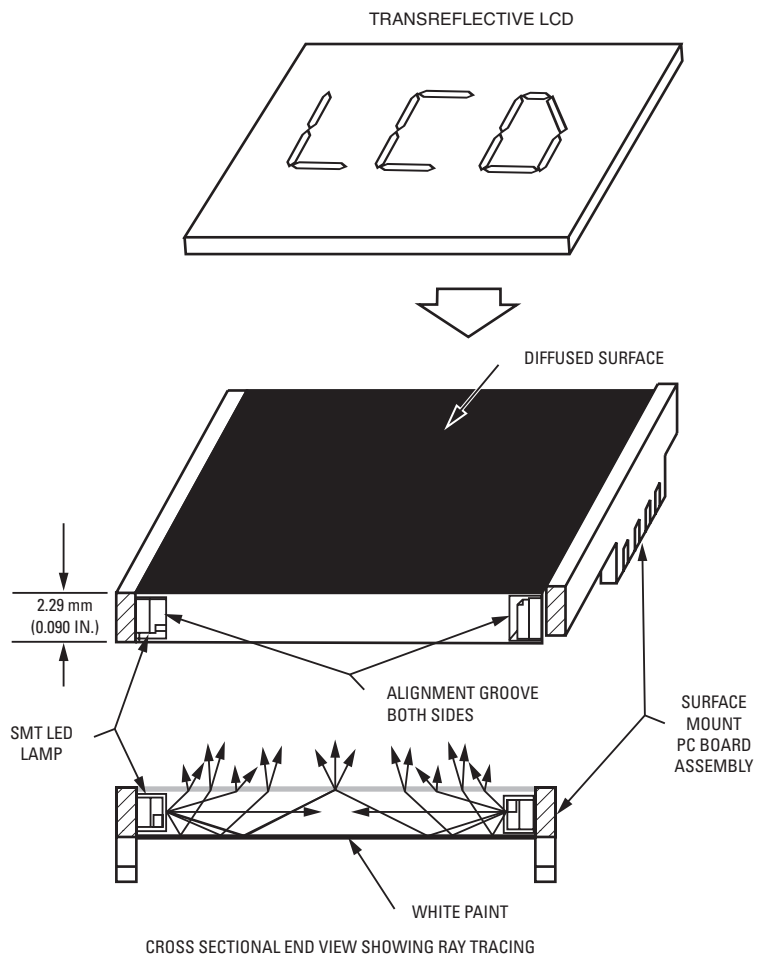
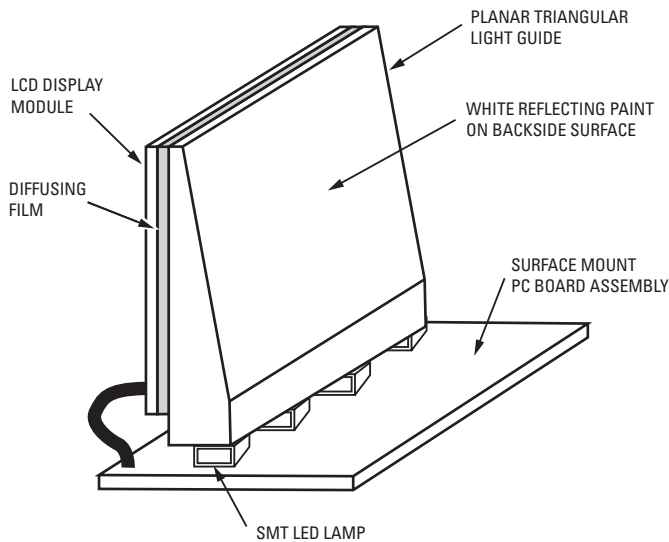

Figure 18. A Transreflective LCD Display Backlit with SMT LED Lamps, Surface Mounted on Small PC Boards, Using a Simple Flat Planar Light Guide.

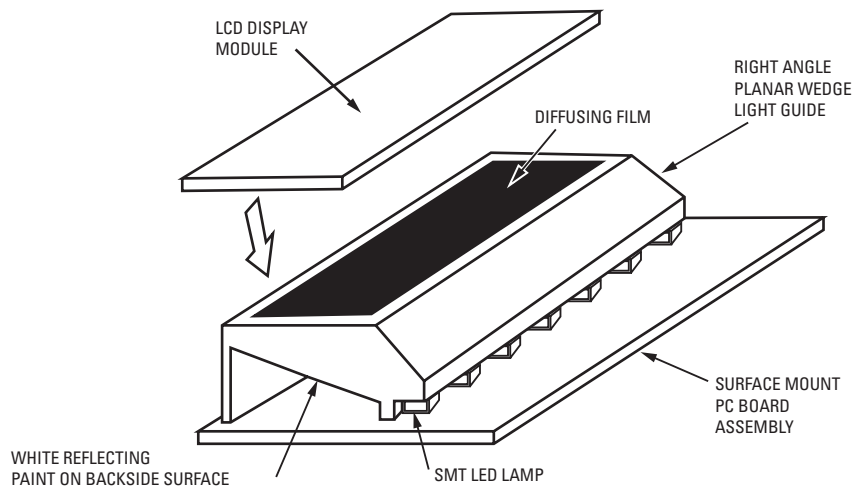



**Figure 19. A Planar Wedge Light Guide used with SMT LED Lamps for Backlighting a Medium Size Transreflective LCD Display.**

illumination. The SMT LED lamps are electrically connected in series on the pc board assembly.

A right angle planar wedge light guide may be used with SMT LED lamps to backlight a medium sized transreflective LCD display that is mounted parallel to a surface mount pc board assembly, as shown in Figure 20a. The SMT LED lamps are spaced on  $\frac{1}{4}$  to  $\frac{1}{2}$  inch spacing to achieve even illumination. The SMT LED lamps are electrically connected in series on the pc board assembly. The ray tracing is shown in Figure 20b.



**Figure 20a. A Right Angle Planar Wedge Light Guide used with SMT LED Lamps for Backlighting a Medium Size Transreflective LCD Display.**

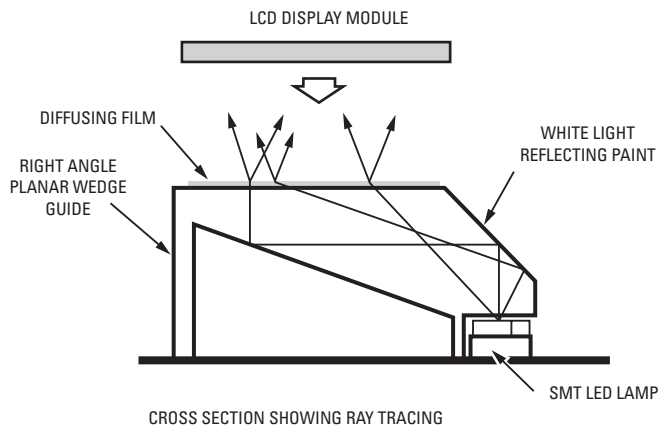

**Figure 20b. Ray Tracing Pattern for A Right Angle Planar Wedge Light Guide used for Backlighting a Medium Size Transreflective LCD Display.**

Untinted, nondiffused T-1  $\frac{3}{4}$  or T-1 LED lamps can also be used with a right angle planar wedge light guide as shown in Figure 21. The spacing for these lamps is between adjacent placement and  $\frac{3}{4}$  inches centers, depending upon the desired luminance.

A dual right angle planar wedge light guide may be used with SMT LED lamps to backlight a medium-large size transreflective LCD display, 4 to 6 inches high by 6 to 9 inches wide, that is mounted parallel to a surface mount pc board assembly, as shown in Figure 22. The SMT LED lamps are spaced on  $\frac{1}{4}$  to  $\frac{1}{2}$  inch centers for both light pipe wedges to achieve even illumination. This technique also provides sufficient illumination for bright ambient lighting conditions. The SMT LED lamps are electrically connected in series-parallel on the pc board assembly, one series string for each side of the light guide.

### Diffusing Films

Diffusing films are made with particles that internally reflect incident light rays so that exit light rays are scattered at random angles, as illustrated in Figure 23. Diffusing films are lossy as some of the incident flux,  $E_v(0)(\text{lm}/\text{m}^2)$ , is reflected and some of the flux is absorbed. The remaining flux exits the diffusing film over a wide radiation pattern that can be described by three parameters:

- 1)  $I_v(0)(\text{cd})$ , the luminous intensity perpendicular to the surface of the film,
- 2)  $\theta_{1/2}$ , the off-axis angle where the luminous intensity is  $\frac{1}{2}$  the on-axis value, and
- 3)  $L_v(0)(\text{cd}/\text{m}^2)$ , the surface luminance.

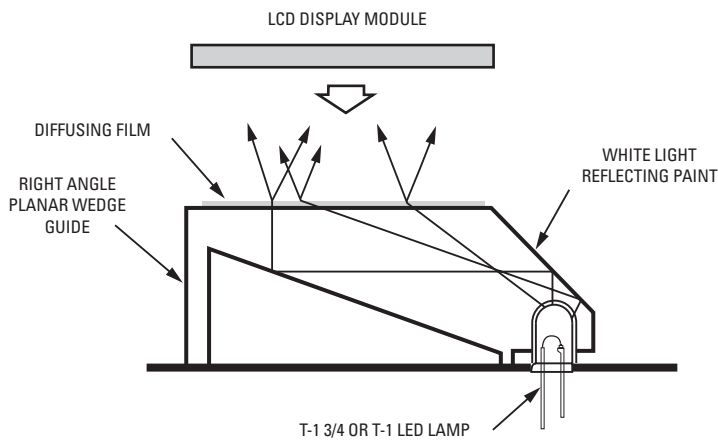

Figure 21. A T-1  $\frac{3}{4}$  or T-1 Untinted, Nondiffused LED lamp Used as the Light Source for a Right Angle Planar Wedge Light Guide.

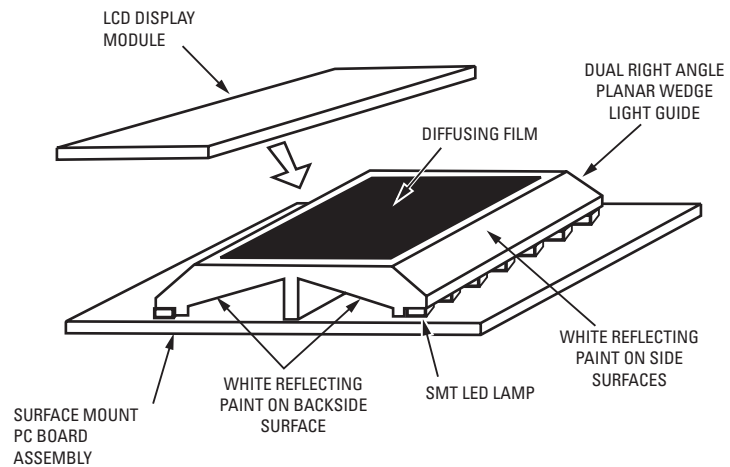

Figure 22. A Dual Right Angle Planar Wedge Light Guide used with SMT LED Lamps for Backlighting a Medium-Large Size Transreflective LCD Display.

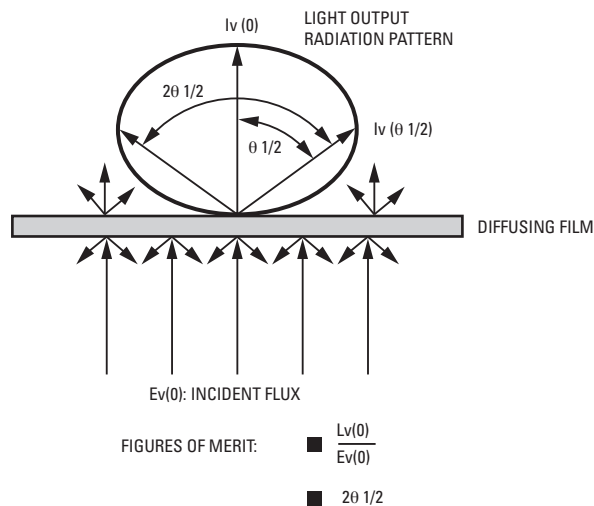

Figure 23. Properties and Figures of Merit of a Diffusing Film.

A diffusing film with a Lambertian radiation pattern has a  $\theta_{1/2}$  value of 60 degrees, and is the maximum viewing angle performance that can be achieved with a diffuser.

Figures of merit for comparing one diffusing film with another are:

- $L_v(0)(\text{cd}/\text{m}^2)/E_v(0)(\text{lm}/\text{m}^2) =$  The ratio of on-axis luminance to incident flux.

Where:  $L_v(0)(\text{cd}/\text{m}^2) = \frac{I_v(0)(\text{cd})}{A(\text{m}^2)}$ , and  
 $A(\text{m}^2) =$  a selected area of the diffusing film surface.

- $2\theta_{1/2} =$  The viewing cone angle.

Using these figure of merit parameters, a trade-off between output luminance and radiation pattern must then be made in selecting a diffusing film in order to achieve desired overall illumination performance in combination with a light guide. The higher the value of the  $L_v(0)/E_v(0)$  ratio, the brighter is the output luminance through the diffusing film for illuminating an LCD display. Also, the wider is the  $2\theta_{1/2}$  angle, the better will be the output radiation pattern (viewing cone angle) from the diffusing film, reducing the chance of an LCD display appearing brighter in the center than at the outer edges. The following companies supply diffusing films:

#### Optical Systems

3M Safety and Security Systems Division, 3M Center, Building 225-4N-14  
St. Paul, MN 55144-10000  
1-(800)-328-7098

Products:

#### Diffusion Films:

Type 100, 5 mils,  $2\theta_{1/2} = 26^\circ$ .  
Type 070, 10 mils,  $2\theta_{1/2} = 32^\circ$ .  
Type 050, 16 mils,  $2\theta_{1/2} = 36^\circ$ .  
Type 040, 20 mils,  $2\theta_{1/2} = 40^\circ$

#### Brightness Enhancement Film (BEF)

##### Miles, Inc.

Polymers Division  
Mobay Road, Bldg. 8  
Pittsburgh, PA 15205-9741  
(412) 777-2000 FAX: (412) 777-2021  
Products:

##### Makrofol BL 6-2:

a pigment filled polycarbonate film, 8 and 16 mil thicknesses,  $2\theta_{1/2} = 18^\circ$  and  $36^\circ$ .

**Makrofol LT 6-4:** a glass fiber filled polycarbonate film, 16 to 20 mil thicknesses,  $2\theta_{1/2} = 16^\circ$ .

##### Physical Optics Corporation

20600 Gramercy Place Bldg. 100  
Torrance, CA 90501  
(310) 320-3088 Fax: (310) 320-8067  
Products: **Beam Homogenizing Light Shaping Diffusing Films.**

#### Illumination Patterns

Luminous intensity variations, as measured across the exit surface of a light guide or a light guide/diffusing film combination, determine the evenness of illumination. The ideal would be to have a perfect rectangularly shaped illumination pattern so that the luminous intensity is the same at all points across the surface, the edges, the corners, and the center all be at the same luminance. An approximation to this ideal is shown in Figure 24a, where the illumination is flat across the surface, falling off smoothly at the edges. However, in a good design there are typically minor luminous intensity variations across the surface as shown in Figure 24b.

These variations should not exceed 20% of the luminous intensity at the center.

Figures 24c - 24f show various luminous intensity patterns that produce unacceptable illumination variations across the face of an LCD display and should be avoided. Careful optical design of the light guide and selection of the proper diffusing film to reduce luminous intensity variations should produce an acceptable illumination pattern equivalent to Figure 24a or 24b.

#### Backlighting Flat Surface Annunciator Panels Made with a Diffusing Film

Flat plate light guides, wedge light guides, and right angle and dual right angle wedge light guides, with either SMT LED or standard T-1 3/4 and T-1 LED lamps, are ideal for illuminating flat surface annunciator panels. The techniques shown in Figures 18 through 24 directly apply to annunciators that are the same size as the LCD modules. Typically, annunciators are made by silk-screening opaque letters and symbols on the surface of a diffusing film, leaving open a background area for illumination. The most effective approach is to silk-screen the message on the backside surface so it cannot be damaged. The diffusing film is placed directly onto the light emitting surface of the light guide to form the annunciator unit. In the "off" condition, the background surrounding the message is dark and without color. When illuminated, the bright color of the LED light readily signifies to an observer the "on" condition of the annunciator. The opaque letters and symbols forming the message are easy to read against the illuminated background.

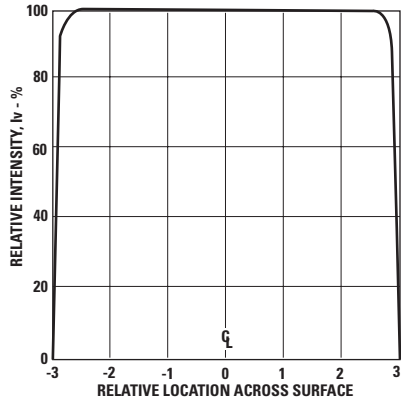

a. An Ideal Illumination Pattern.

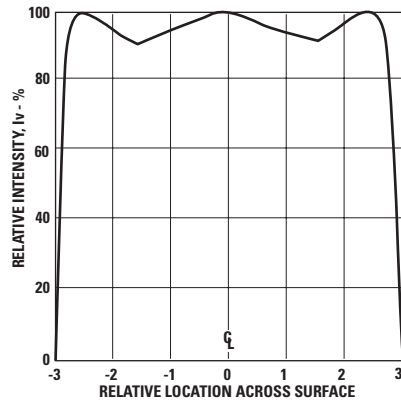

b. Achievable Good Illumination Pattern.

Figures a & b: Ideal and Achievable Illumination Patterns.

These same concepts may be applied to making small sized annunciators utilizing the light pipes described in the following section. In many cases, silk-screening an opaque background, leaving open letters or a symbol, is most effective. The silk-screened diffusing film is glued to the exit surface of the light pipe with an optically clear adhesive to form the annunciator module. In the “off” condition, the letters or symbol are dark and without color and tend to blend with the background. In the “on” condition, the bright letters or symbol, with the color of the LED light, stand out vividly contrasting in appearance against the background.

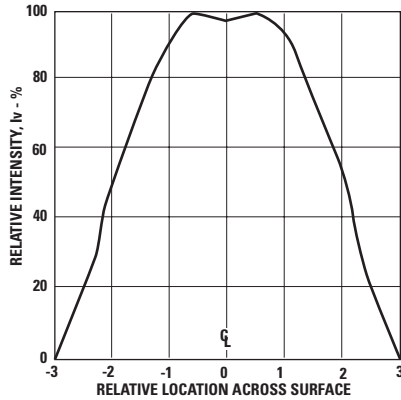

c. Center Illumination Brighter than at Edges.

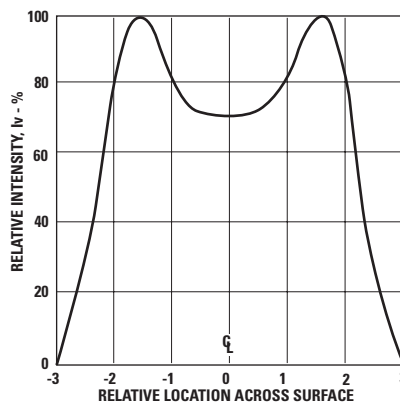

d. Edge Illumination Brighter than at the Center.

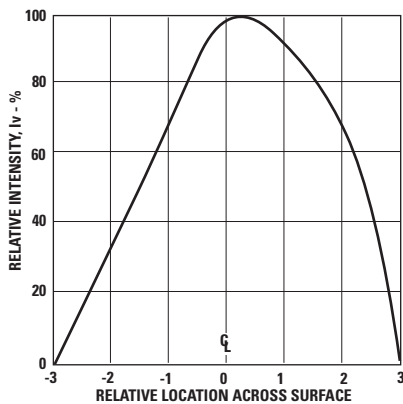

e. Uneven Illumination Across Surface.

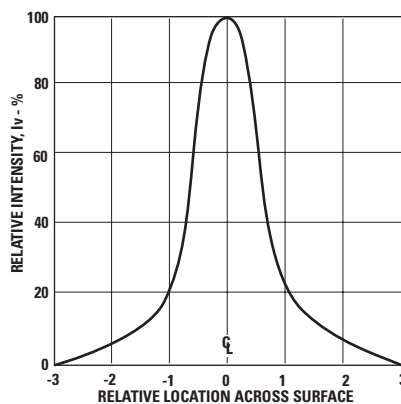

f. Illumination with a Center Hot Spot.

Figures c - f: Unacceptable Illumination Patterns.

Figure 24. Illumination Patterns of Various Light Guide/Diffusing Film Combinations.

**Simple Shaped Light Pipes for Front Panel Indication**

Light guides for front panel indication are typically called “light pipes.” Light pipes can be made in many simple and compound shapes. Simple cylindrical, rectangular, and triangular shaped light pipes are illustrated in Figure 25, utilizing an SMT LED as the light source. These simple light pipes can be made from commercially available plastic rod.

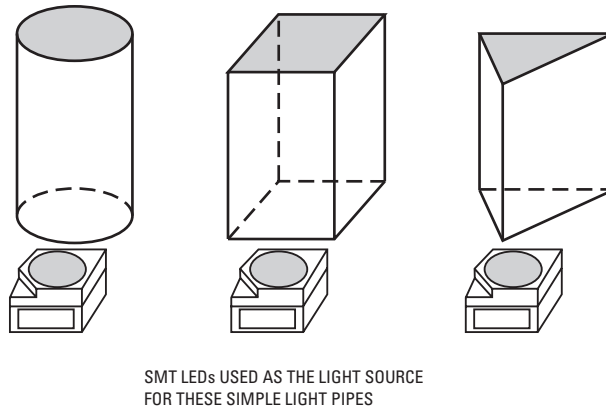

**Figure 25. Simple Light Pipe Shapes for Use as Front Panel Indicators Using an SMT LED as the Light Source.**

**Custom Shaped Light Pipes for Front Panel Indication**

Custom shapes, usually precision molded, are designed to achieve special effects, as illustrated in Figure 26. Two or more LED light sources may be needed to illuminate a large arrow shaped light pipe. A “three legged” light pipe may be used to give a three condition status in a single indicator, red for “danger”, yellow for “caution”, and green for “safe”.

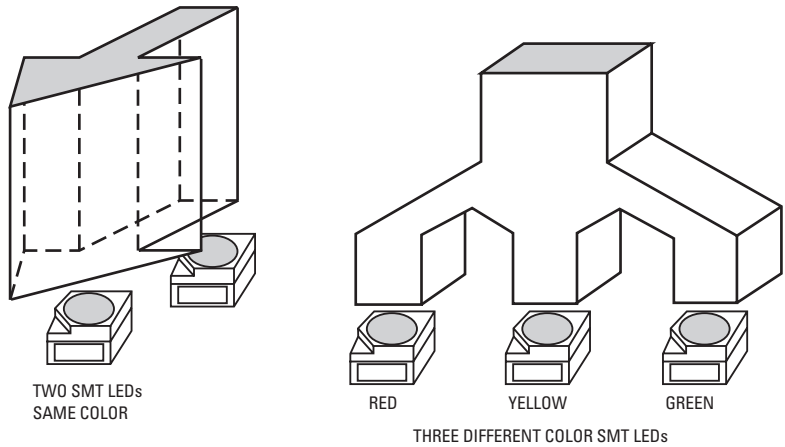

**Figure 26. Custom Shaped Light Pipes for Use as Front Panel Indicators.**

**Compound Shaped Light Pipes for Front Panel Indication**

Compound light pipe configurations may also be precision molded for specialized applications. The serpentine light pipe, shown in Figure 27, is designed to move light around an obstruction. The light ray reflections follow the curvature of the light pipe without loss.

**Multiple Element Light Pipe Arrays**

Multiple element light pipe arrays may be molded as a single piece part. Figure 28a shows a four element linear light pipe array molded as a single piece part. The thickness of the tie plate (or tie bar) should be sufficient to provide the necessary level of support for correct positioning of each light pipe element. For the assembly shown, the 0.254 mm (0.010 in.)

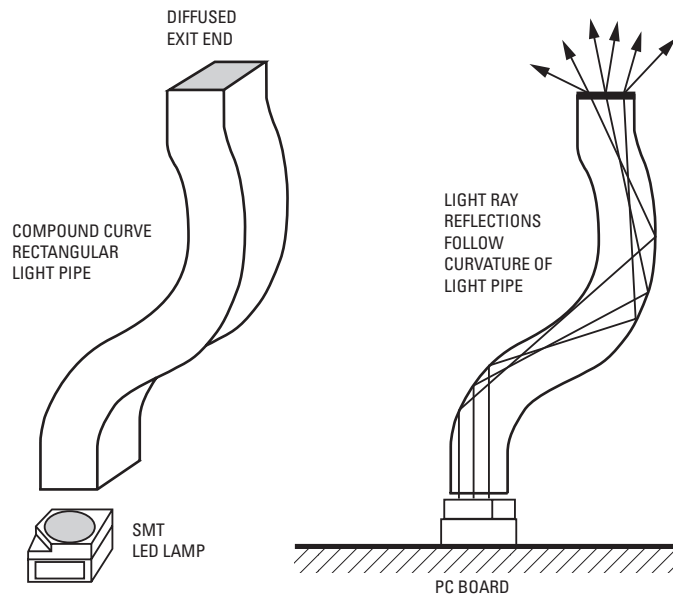

**Figure 27. A Serpentine, Rectangular Light Pipe Designed to Move Light Around an Obstruction.**

thick tie plate is flexible, permitting manual adjustment of each light pipe as the array is installed in the next assembly. The 2.54 mm (0.100 in.) thick tie bar in Figure 28b is rigid, holding the four serpentine bar elements in precise position to assure accurate placement into the next assembly. Since the thin tie plate and rigid tie bar are perpendicular to the light pipes, cross coupling of scattered light from an illuminated light pipe element is minimal, and will not illuminate adjacent light pipe elements.

**Tinted, Diffused vs. Untinted, Nondiffused LED Lamps as Emitters for Light Pipes**

In most cases, untinted, nondiffused LED lamps with semi-wide flux radiation patterns of 24 degrees, or larger, are preferred emitters for light guides and light pipes. However, there are designs where a tinted, diffused LED lamp with a wide radiation pattern of 45 to 60 degrees is the preferred emitter. This concept is illustrated in Figure 29. The semi-wide radiation pattern of a T-1 3/4 untinted, nondiffused LED lamp fits the requirements of a long “slim” light pipe. However, a short “stocky” light pipe requires an LED lamp with a wide flux radiation pattern to prevent a “hot spotty” appearance at the exit end that may be caused by using a lamp with a narrower radiation pattern.

**Molded, Flexible, Diffused, Light Pipe Arrays**

Flexible, diffused, light pipe arrays are very effective in backlighting keypads and indicator windows in front panel assemblies. Flexible light pipe arrays are usually molded from an untinted, diffused, optical grade silicone rubber, such as 150-OU, supplied by Tory Rubber Company, a division of Dow Corning. As illustrated in

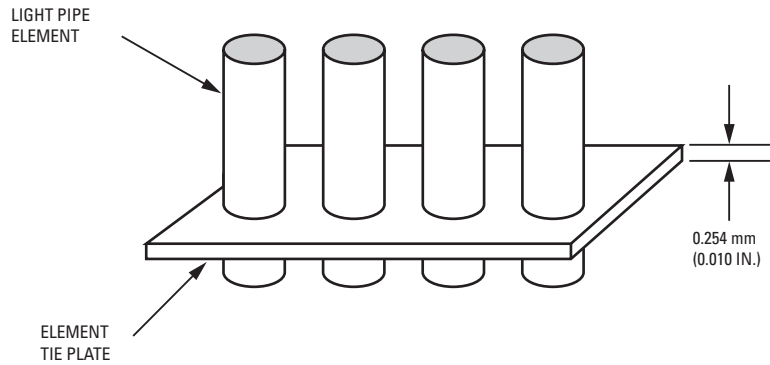

**Figure 28a. A Four Element Light Pipe Linear Array, Molded as a Single Piece Part with a Flexible Tie Plate.**

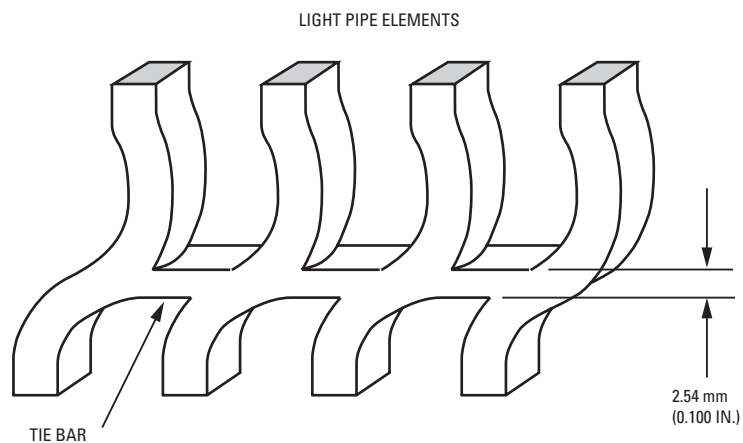

**Figure 28b A Four Element Serpentine Light Pipe Linear Array, Molded as a Single Piece Part with a Rigid Tie Bar.**

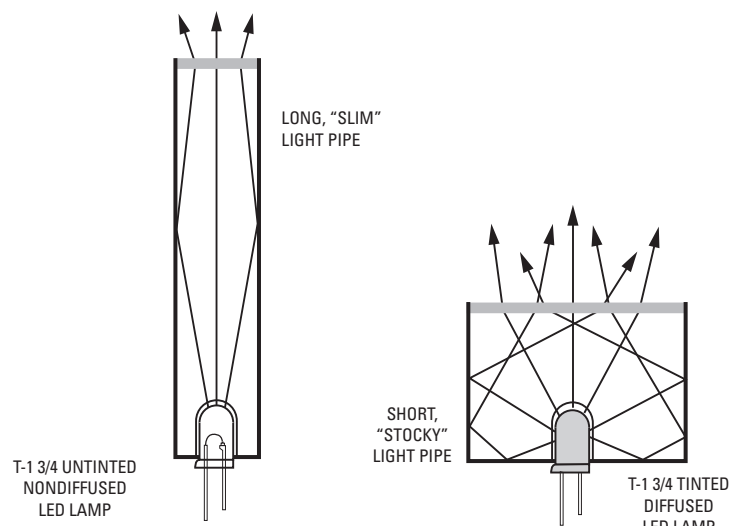

**Figure 29. Conceptual Use of Tinted, Diffused and Untinted, Nondiffused LED Lamps as Emitters in Different Light Pipe Configurations.**

Figure 30a, the individual light pipe elements are short in length, are either solid or hollow inside, and vary in size and shape. The SMT LED lamps fit up against the bases of solid light pipe elements, or fit inside hollow light pipe elements, as illustrated in Figure 30b. The light pipe array is placed over an SMT LED lamp pc board assembly to form a backlighting unit, as illustrated in Figure 30b. A bright, wide angle illumination pattern is achieved at the exit end of each light pipe element. A pc board assembly with standard T-1  $\frac{3}{4}$  or T-1 LED lamps may also be used, with the lamps fitting inside the hollow elements of the flexible light pipe array. The backlighting unit is then mated with the keypad and front cover to form the illuminated front panel assembly. The push button caps in the keypad are molded from untinted, nondiffused acrylic or polycarbonate. The indicator windows in the front cover are untinted and usually nondiffused. Both the key caps and windows may be diffused if desired. The wide illumination pattern from each diffused light pipe element assures an even illumination and wide viewing angle for each push button cap and front panel indicator window. In some panel designs, the indicator windows are cut-outs in the front panel cover, allowing solid light pipe elements to protrude about 2.54 mm (0.100 in.). This makes a pleasing design, adding some depth to a front panel configuration.

The following company designs and molds flexible diffused light pipe arrays for backlighting

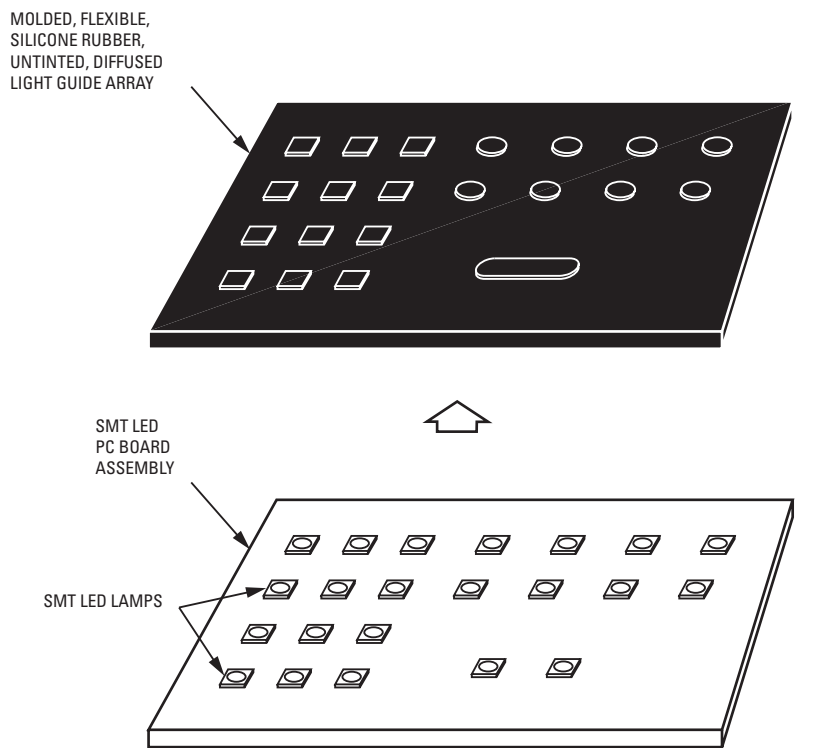

**Figure 30a. A Molded, Flexible, Silicone Rubber, Untinted, Diffused Light Pipe Array used in Combination with an SMT LED PC Board.**

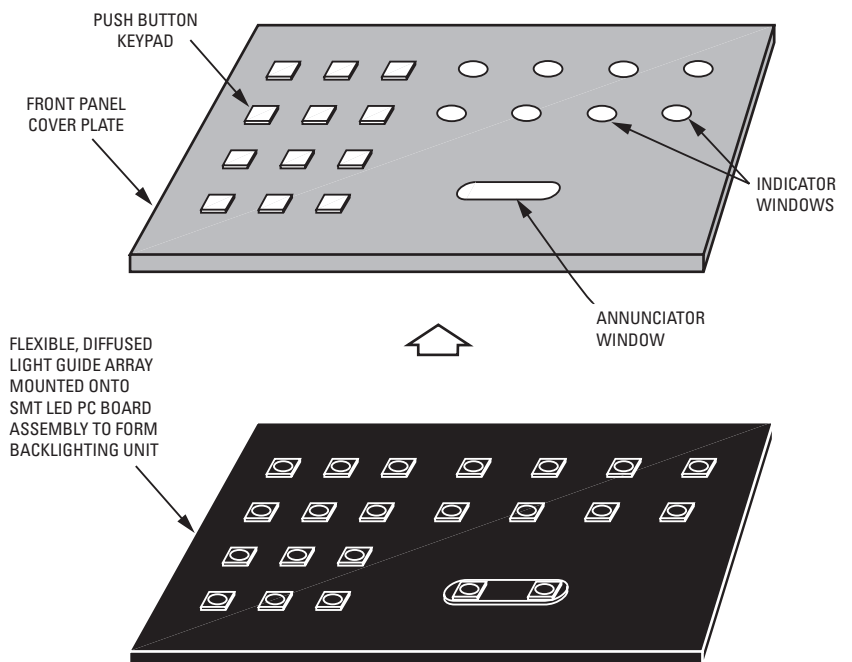

**Figure 30b. The Flexible, Diffused Light Pipe Array and SMT LED PC Board Form a Backlighting Unit. This Backlighting Unit Illuminates a Push Button Keypad and Front Panel Assembly.**

keypads and indicator windows in front panel assemblies. Diffused silicone rubber 150-OU is the material used.

Keytek  
 44 Old State Road #3  
 New Milford, CT 06776  
 (203) 350-1153  
 FAX: (203) 350-1155

**Light Pipe Output Radiation Patterns**

The light output radiation pattern from the exit end of a light pipe should be designed to meet the luminance and viewing angle requirements in a defined ambient lighting environment. A trade-off is made between on-axis intensity and radiation pattern, as illustrated in Figure 31. A wide radiation pattern, at the expense of on axis intensity,  $I_v(0)$ , is better for a wide off-axis viewing angle. This is suitable for most applications in moderate ambient lighting conditions less than 1000 fc. For bright ambient light conditions, such as for outdoor viewing, radiation pattern is reduced to achieve a high on-axis intensity.

A designer may measure the light output radiation pattern from the exit end of a light pipe using a goniometer. The goniometer rotating detector should be at a nominal distance of 305 mm (12 in.) from the exit end of the light guide. Radiation pattern (viewing angle) curves are obtained, similar to those shown in Figure 32.

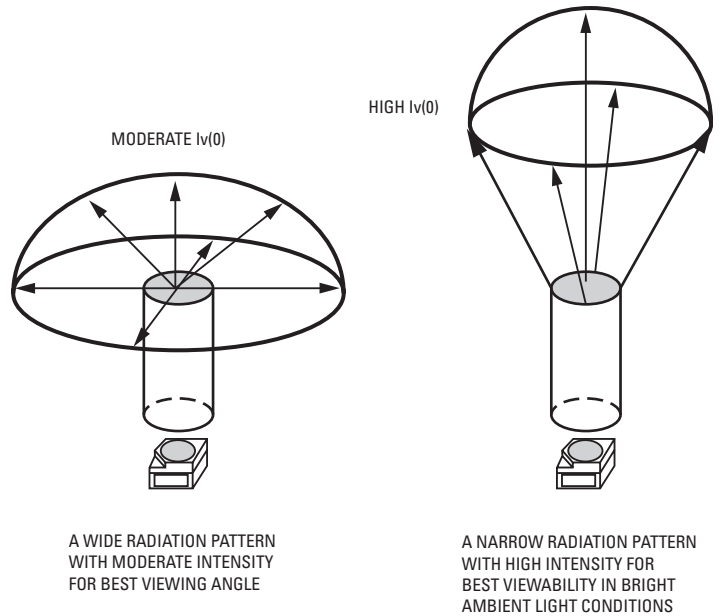

**Figure 31. Wide and Narrow Light Pipe Radiation Patterns.**

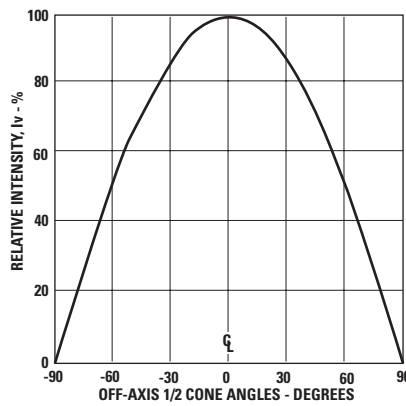

**A Wide Radiation Pattern for Best Viewing Angle with Moderate On-Axis Intensity.**

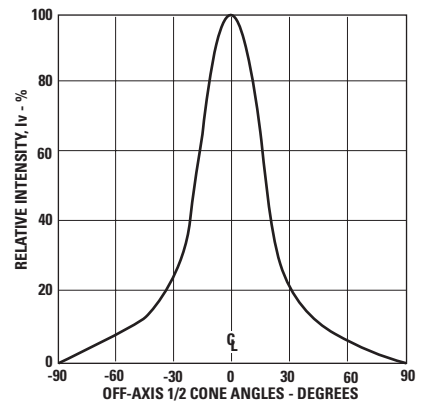

**A Narrow Radiation Pattern with a Small Viewing Angle and High On-Axis Intensity.**

**Figure 32. Wide and Narrow Light Pipe Output Radiation Patterns Obtained using a Goniometer.**



### Edge Lighting a Transparent Flat Plate with Grid Lines

A flat transparent plate with engraved or etched grid lines on the face surface may be edge lighted with LED lamps, as shown in Figure 33a. The face surfaces of a transparent flat plate are smooth for an observer to see through. The surfaces of the grid lines are rough to give the necessary diffusing surface. The grid lines may be coated with a thin layer of white translucent paint to enhance daylight readability, with some loss in grid illumination. All four edges of the light plate may be painted with white reflecting paint.

Light within the light plate is internally reflected by all surfaces, and escapes only through the diffused lines providing the grid line illumination, as shown in Figure 33b. Holes are drilled into two opposite ends to accept the domes of HLMP-650X subminiature lamps. The LED lamps are epoxied to the transparent plate and electrically wired in series. The rectangular bases of the LED lamps are not inserted into the light plate in order to keep the plate thickness at 2.54 mm (0.100 in.). The number of LED lamps required, spaced on approximately  $\frac{1}{4}$  to  $\frac{1}{2}$  inch centers, is determined by the size of the light plate and the desired luminance of the grid lines.

A transparent plate with engraved or etched grid lines may also be edge lighted using surface mounted SMT LED lamps as shown in Figure 34. Two surface mount pc board assemblies are mounted to the sides of the transparent plate for even illumination of the grid lines. Optional grooves are cut into the

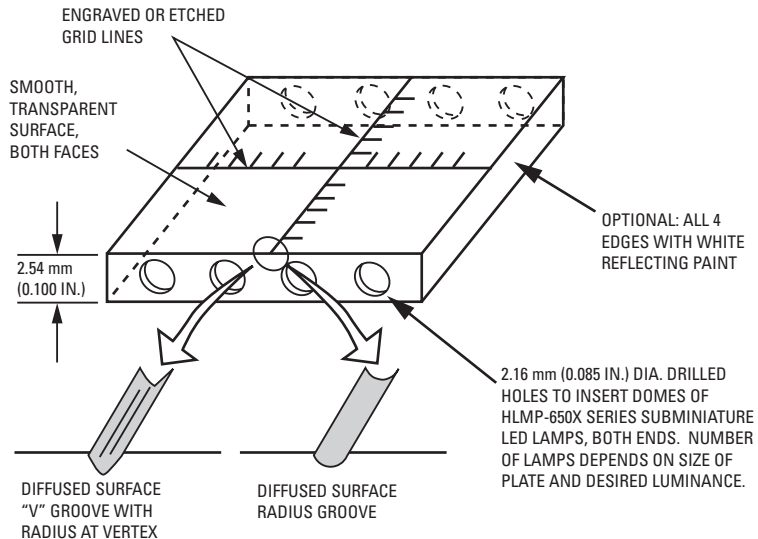

**Figure 33a. A Transparent Flat Plate with Engraved or Etched Grid Lines Illuminated by Subminiature LED Lamps, Epoxied to the Plate.**

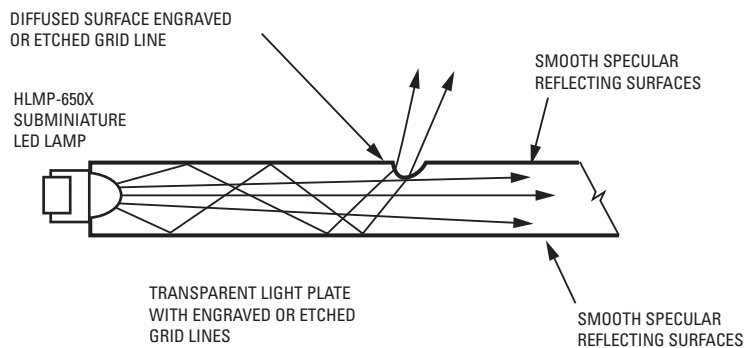

**Figure 33b. Internal Reflecting Light Rays Escaping Only Through Engraved or Etched Diffused Grid Lines.**

plate to provide alignment of the pc board assembly with the plate. The number of SMT LED lamps, spaced on  $\frac{1}{4}$  to  $\frac{1}{2}$  inch centers, depends upon the size of the transparent plate and the required illumination of the grid lines. Advantages of this approach are:

- 1) the minimum thickness of the transparent plate, typically 2.29 mm (0.090 in.) with optional grooves to

- enclose the SMT LED lamps, or 2.03 mm (0.080 in.) without grooves for minimal plate thickness, and
- 2) the LED lamps are not epoxied to the transparent plate.

### Light Guide Vendors

The following plastic molding companies offer light guide optical design assistance and/or can develop prototypes.

Nitto Jushi Kogyo Co., LTD.  
 Distributor: Astra Products Inc.  
 P.O. Box 479, Baldwin, NY 11510  
 (516) 223-7500 Fax: (516) 868-2371

C-Plastics, 243 T Whitney Street  
 Leominster, MA 01453  
 (508) 534-6876 Fax: (508) 537-8238

Lexalite, 10163 US Highway 31 North  
 P.O. Box 498, Charlevoix, MI 49720  
 (616) 547-6584 Fax: (616) 547-5833

AO Tech, Division of American Optical Corp., 14 Mechanics St., P.O. Box 746  
 Southbridge, MA 01550  
 (508) 765-9711 Fax: (508) 765-2158

NiOptics Corp. 1801 Maple Ave.  
 Evanston, IL 60201  
 (708) 491-2177 Fax: (708) 467-1244

Industrial Devices Inc. (IDI)  
 260 Railroad Avenue  
 Hackensack, NJ 07601  
 (201) 489-8989 Fax: (201) 489-6911

U.S. Precision Lens, 3997 McMann Rd.  
 Cincinnati, OH 45245  
 (513) 752-7000 Fax: (513) 752-2841

KHATOD OPTOELECTRONICS  
 20092 Cinisello Balsamo  
 (Milan) Italy Via Monfalcone  
 +39 02 66013695 Fax: +39 02 66013500

### MIL-P-7788F LED Lighted Aircraft Panel

Figure 35 illustrates the basic construction of an acrylic aircraft LED lighted panel assembly meeting the requirements of MIL-P-7788F. This internally lighted panel uses HLMP-650X untinted, nondiffused, SMT subminiature LED lamps surface mounted on a double sided pc board. Maximum metalization is used on both sides to achieve a low thermal resistance

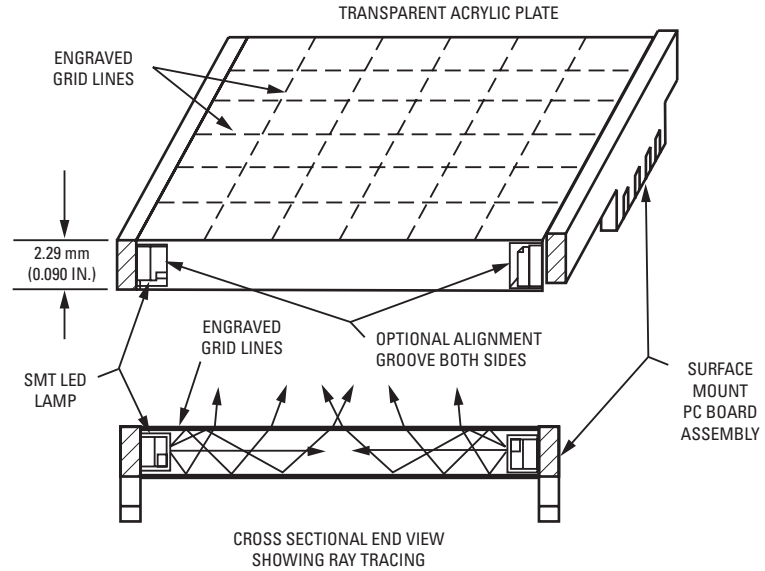

**Figure 34. A Transparent Flat Plate with Engraved or Etched Grid Lines Illuminated by SMT LED Lamps on Small Surface Mount PC Board Assemblies.**

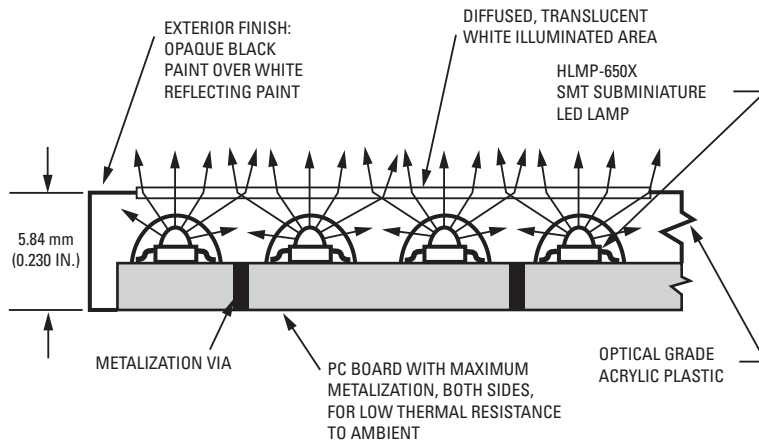

**Figure 35. Basic Construction of a MIL-P-7788F LED Lighted Aircraft Panel, Shown in Simplified Cross Section.**

to ambient.

The LED lamps are distributed throughout the panel to achieve a desired lighting effect. Flux coupling into the panel is 100%. Light rays from the LED lamps blend together within the panel to produce even illumination through the illuminated areas on the face of the panel. These illuminated areas are diffused and coated with a thin layer of translucent white paint. In daylight, the LED lamps are off, and the illumination areas appear white by reflecting ambient light. At night, these areas are internally illuminated by the LED lamps and

appear the same color as the LED light. All exterior surfaces of the panel are painted with a white reflecting paint, leaving open the areas on the face of the panel to be internally illuminated. An overcoat of black, scratch resistant paint is added to form the exterior finish. The overall thickness of the panel is 5.84 mm (0.230 in.).

### Coupling an Optical Fiber to an LED Lamp

The most effective method to couple an optical fiber to an LED lamp is to insert the fiber into the lamp package in close proximity to the LED chip. This assures the

most efficient flux coupling and light capture by the optical fiber, although only a small portion of the LED emitted flux is actually captured by the fiber. The procedure is illustrated in Figure 36a.

1. With a jeweler's lathe, cut off the top of the dome package to obtain a flat, semi-smooth surface.
2. Looking through the flat surface with a microscope, visually locate one

corner of the LED chip opposite the wire bond, as shown in Figure 36b.

3. Precision drill an insertion hole down to the located corner, stopping at a minimum distance of 0.5 mm (0.020 in.) above the LED chip. Do not come in contact with the wire bond or LED chip.
4. With a syringe, insert a clear, room temperature curing epoxy into the hole.
5. Immediately insert the optical fiber

into the hole with a steady rotary motion to assure no air bubbles.

6. Let the epoxy cure for the required length of time.

The optical fiber is now anchored to the LED lamp package. The flux emanating from the corner of the LED chip is captured by the entrance end of the optical fiber with minimal loss.

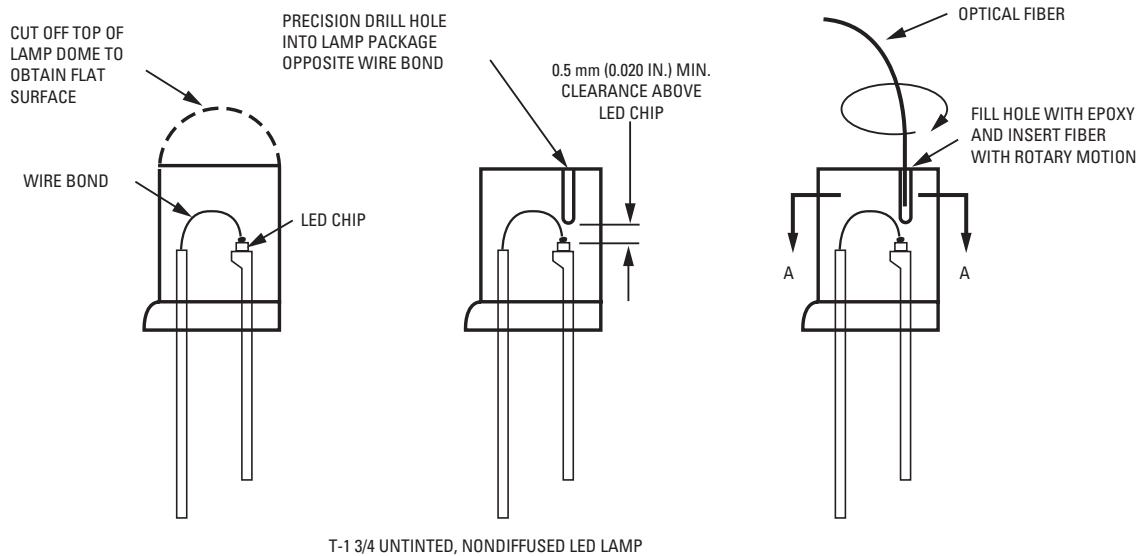

Figure 36a. Technique for Coupling an Optical Fiber to an LED Lamp

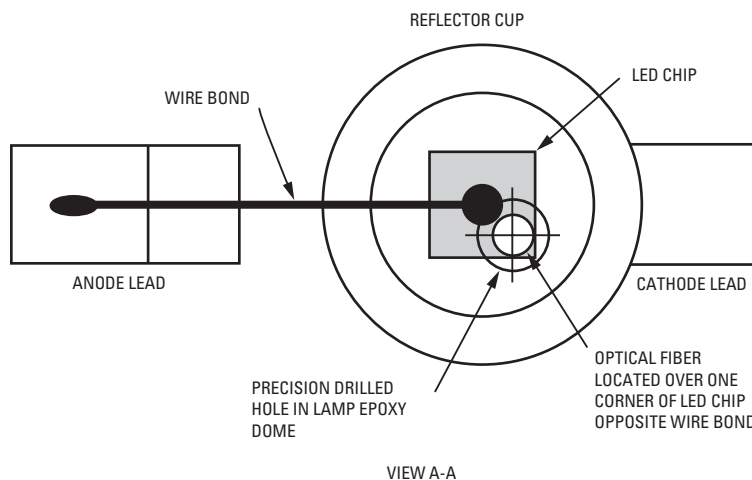

Figure 36b. Positioning of Optical Fiber With Respect to the LED Chip.

**List of LED Lamps, Untinted, Nondiffused, Recommended for use in Light Guide Applications**

**T-1 3/4 LED Lamps**

Part Number	LED and Color	Viewing Angle	Iv, mcd (at 20 mA)	
			Min.	Typ.
HLMP-3750	GaP - 626 nm High Efficiency Red	24°	90	125
HLMP-3850	GaP - 585 nm Yellow	24°	96	140
HLMP-3950	GaP - 570 nm Green	24°	111	265
HLMP-C025-P0000	AS AlInGaP - 625 nm Red	25°	500	1000
HLMP-C225-O0000	AS AlInGaP - 590 nm Amber	25°	450	800
HLMP-C625-P0000	AS AlInGaP - 637 nm Deep Red	25°	500	700
HLMP-DB25-P0000	GaN - 462 nm Blue	25°	40	100
HLMP-DM25-M0000	InGaN - 527 nm Green	25°	245	970
HLMP-DS25-R0000	InGaN - 470 nm Blue	25°	100	260
HLMP-EL24-PS000	AS AlInGaP - 590 nm Amber	23°	765	—
HLMP-EG24-PS000	AS AlInGaP - 626 nm Red	23°	765	—
HLMP-EL25-SV000	TS AlInGaP - 592 nm Amber	23°	1650	—
HLMP-ED25-TW000	TS AlInGaP - 630 nm Red	23°	2170	—
HLMP-EL30-MQ000	AS AlInGaP - 590 nm Amber	30°	450	—
HLMP-EG30-NR000	AS AlInGaP - 626 nm Red	30°	590	—
HLMP-EL31-SV000	TS AlInGaP - 592 nm Amber	30°	1650	—
HLMP-ED31-SV000	TS AlInGaP - 630 nm Red	30°	1650	—
HLMP-CB15-P0000	InGaN - 472 nm Blue	15°	765	—
HLMP-CM15-S0000	InGaN - 525 nm Green	15°	1650	—
HLMP-CB30-K0000	InGaN - 472 nm Blue	30°	270	—
HLMP-CM30-M0000	InGaN - 525 nm Green	30°	450	—
HLMP-EL24-SV000	AS AlInGaP - 590 nm Amber	23°	1650	—
HLMP-EL30-SV000	AS AlInGaP - 590 nm Amber	30°	1650	—

**T-1 LED Lamps**

Part Number	LED and Color	Viewing Angle	Iv (20 mA) mcd
HLMP-K105	AS AlGaAs - 637 nm Red	45°	65
HLMA-KL00	AS AlInGaP - 592 nm Amber	45°	200
HLMA-KH00	AS AlInGaP - 615 nm Red-Orange	45°	200
HLMP-1340	GaP - 626 nm High Efficiency Red	60°	55
HLMP-1440	GaP - 585 nm Yellow	60°	45
HLMP-1540	GaP - 570 nm Green	60°	45

### SMT Subminiature LED Lamps

Part Number	LED and Color	Viewing Angle	Iv (20 mA) mcd
HLMP-Q105	AS AlGaAs - 639 nm Red	28°	200
HLMA-QL00	AS AlInGaP -592 nm Amber	15°	500
HLMA-QH00	AS AlInGaP - 615 nm Red-Orange	15°	500
HLMP-6305	GaP - 626 nm High Efficiency Red	28°	40
HLMP-6405	GaP - 585 nm Yellow	28°	20
HLMP-6505	GaP - 570 nm Green	28°	40

### SMT LED Lamps

Part Number	LED	Color	Viewing Angle	Iv (20 mA) mcd
HSMS-A100-J00J1	GaP	Red	120°C	15
HSMH-A100-L00J1	AS AlGaAs	Red	120°C	50
HSMC-A100-Q00J1	AS AlInGaP	Red	120°C	100
HSMZ-A100-R00J1	TS AlInGaP	Red	120°C	400
HSMJ-A100-Q00J1	AS AlInGaP	Red Orange	120°C	200
HSMV-A100-R00J1	TS AlInGaP	Red Orange	120°C	350
HSM D-A100-J00J1	GaP	Orange	120°C	15
HSM L-A100-Q00J1	AS AlInGaP	Orange	120°C	160
HSM A-A100-Q00J1	AS AlInGaP	Amber	120°C	12
HSM U-A100-R00J1	TS AlInGaP	Amber	120°C	100
HSM Y-A100-J00J1	GaP	Yellow	120°C	270
HSM G-A100-J02J1	GaP	Yellow Green	120°C	18
HSM G-A100-H01J1	GaP	Emerald Green	120°C	8
HSM M-A100-S00J1	InGaN	Green	120°C	280
HSM M-A101-R00J1	InGaN	Green	120°C	200
HSM K-A100-S00J1	InGaN	Cyan	120°C	280
HSM K-A101-R00J1	InGaN	Cyan	120°C	170
HSM B-A100-J00J1	GaN	Blue	120°C	15
HSM N-A100-P00J1	InGaN	Blue	120°C	50
HSM N-A101-N00J1	InGaN	Blue	120°C	70
HSM H-C191	AS AlGaAs	Red	170°C	17
HSM S-C191	GaP	Red	170°C	10
HSM D-C191	GaP	Orange	170°C	8
HSM Y-C191	GaP	Yellow	170°C	8
HSM G-C191	GaP	Yellow Green	170°C	15

Please request Agilent Technologies' *Surface Mount LED Selection Guide* for full SMT LED offering.

**[www.agilent.com/semiconductors](http://www.agilent.com/semiconductors)**

For product information and a complete list of distributors, please go to our web site.

For technical assistance call:

Americas/Canada: +1 (800) 235-0312 or  
(916) 788-6763

Europe: +49 (0) 6441 92460

China: 10800 650 0017

Hong Kong: (+65) 6271 2451

India, Australia, New Zealand: (+65) 6271 2394

Japan: (+81 3) 3335-8152(Domestic/International), or  
0120-61-1280(Domestic Only)

Korea: (+65) 6271 2194

Malaysia, Singapore: (+65) 6271 2054

Taiwan: (+65) 6271 2654

Data subject to change.

Copyright © 2002 Agilent Technologies, Inc.

Obsoletes 5988-5086EN

September 23, 2003

5988-7057EN



**Agilent Technologies**